

ATIKOKAN AMATEUR RADIO CLUB

# Basic Course Student Notes

---

Version 1.02, 2012 edition

**Warren Paulson, VE3FYN**

Revised  
6 February 2012

These notes summarize the 1000 questions in the Canadian Amateur Radio Basic exam question bank, and are organized according to the Basic Study Guide chapters. These notes are meant to be used in conjunction with the manual and a Basic Course.

---

---

## TABLE OF CONTENTS

---

---

TABLE OF CONTENTS.....	ii
BATTERIES (CH 2) .....	1
CONDUCTORS AND INSULATORS (CH 2).....	1
ALTERNATING CURRENT (Ch 2).....	1
MAGNETISM (Ch 2) .....	2
METERS (Ch 2).....	2
RESISTORS (CH 2) .....	3
Resistor Colour Codes .....	3
OHM'S LAW (CH 3).....	4
A parallel example: .....	5
A series example: .....	6
INDUCTORS AND CAPACITORS (CH 4).....	7
WAVES, WAVELENGTH, FREQUENCY AND BANDS (CH 5) .....	9
Amateur Radio HF / VHF Bands .....	9
Amateur Radio Emission Modes .....	10
PROPAGATION (CH 6) .....	11
Miscellaneous .....	11
Sunspots and Solar Activity.....	11
Ionosphere .....	12
TRANSMISSION LINES (CH 7).....	13
ANTENNAS (CH 8).....	15
ACTIVE DEVICES: DIODES, TRANSISTORS AND TUBES (CH 9).....	18
POWER SUPPLIES (CH 10) .....	21
ESTABLISHING AND EQUIPPING AN AMATEUR STATION (CH 11) .....	23
ROUTINE OPERATION OF AN AMATEUR STATION (CH 12).....	26
MODULATION AND TRANSMITTERS (CH 13) .....	29
RECEIVERS (CH 14) .....	34
INTERFERENCE (CH 15) .....	36
SAFETY (CH 16).....	38

**Note to readers:** This document is intended to address the Basic exam questions, and therefore some topics may appear incomplete (such as the resistor colour-code table). However, it is my intent to be accurate. To that end, please report any errors, inconsistencies or ambiguities to [ve3fyn@gmail.com](mailto:ve3fyn@gmail.com).

## BATTERIES (CH 2)

---

**Note:** Some of the points in the next few sections are covered in more detail in Chapter 3.  
Conversions are covered in exponents and decibels, later in the course.

1. A car battery supplies **12 volts**.
2. A battery has a **positive and negative side**.
3. A **storage cell** can be repeatedly recharged.
4. A lead acid **battery** is a source of EMF.
5. Unlike a conventional flashlight battery, a lead acid battery **can be repeatedly recharged**.
6. A 1.5 volt dry cell, when supplying a lot of current, may drop to 1.2 volts, due to its **internal resistance**.
7. A carbon-zinc flashlight cell can **never** be recharged.
8. A nickel-cadmium battery should never be discharged below **one volt**.
9. A nickel-cadmium battery should never be **short-circuited**.
10. To increase current capacity, connect batteries in **parallel**.
11. To increase voltage, connect batteries in **series**.

## CONDUCTORS AND INSULATORS (CH 2)

---

1. A **conductor** allows electricity to flow easily. It has low resistance.
2. An **insulator** does not easily allow electricity to flow. It is the reciprocal of a conductor.
3. The **resistance** of a conductor changes with **temperature**.
4. Good conductors: gold, silver, aluminum (metals).
5. Good insulators: air, plastic, porcelain glass, wood (non-metals/carbon)
6. Copper is a very good conductor.
7. Resistors get hot as electrical current is converted into **heat**.
8. **Conductance** is the reciprocal (opposite) of resistance.
9. A **short-circuit** has virtually no resistance, allowing too much current to flow.
10. An **open-circuit** is not complete, and allows no current to flow.

## ALTERNATING CURRENT (CH 2)

---

1. **Frequency** is the number of times an alternating current flows back and forth.
  - a. Frequency is measured in Hertz, abbreviated Hz. It is cycles per second.
2. The desired frequency is called the **fundamental frequency**.
3. Signals at multiples and fractions of the fundamental are called **harmonics**.
4. Most people can hear from 20 to 20,000 Hz, called the **audio frequencies**.
5. The duration of one cycle is called the **period**.
  - a. Frequency = 1 / period.
  - b. Period = 1 / frequency.

## MAGNETISM (CH 2)

---

1. Permanent magnets are made from iron or steel.
2. Like poles repel; unlike poles attract.

## METERS (CH 2)

---

1. An ammeter measures current.
  - a. Ammeters are always connected in series with one wire in the circuit.
  - b. An ammeter presents a very low value resistance, thus not affecting the circuit.
2. A multimeter typically measures Voltage, Current, and Resistance
3. Voltmeters are typically connected in parallel with the circuit.
  - a. Voltmeters measure potential difference.

## RESISTORS (CH 2)

1. Most resistors are made of **carbon**.
2. Resistors heat-up because some electrical energy passing through is **converted to heat**.
  - a. Larger resistors **dissipate more heat**, rated in watts.
3. The first three **colour bands** on a resistor indicate its **resistance in ohms**.
  - a. The first two digits indicate the value.
  - b. The third digit indicates the multiplier.
  - c. Brown-black-red: 1000 ohms.
  - d. Red-violet-yellow=270K ohms.
3. You find a resistor's tolerance in percent by reading the **fourth band** of its colour code.
  - a. A 100 ohm resistor with a 10% tolerance may have a value between 90 and 110 ohms.
  - b. Lower tolerances indicate higher-quality resistors.
  - e. A gold band = 5%.
7. Resistor Colour Code:
  - a. Better Be Ready Or Your Great Big Venture Goes West.
  - b. "non-colours" at the ends.
8. When a resistor's temperature increases, its resistance will change according to its **temperature coefficient rating**.

### RESISTOR COLOUR CODES

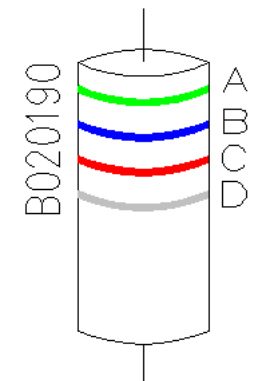
Mnemonic	Colour	Value	Tolerance		
Better	Black	0		<p style="text-align: center;"><b>Example</b></p> <p style="text-align: center;">Green = 5 Blue = 6 Red = 2 zeroes Silver= 10% tolerance</p> <p style="text-align: center;">This resistor would have a value of 5,600 ohms, or 5.6KΩ.</p> <p style="text-align: center;">Its measured value would be 5,040 to 6,160 ohms.</p>	
Be	Brown	1			
Ready	Red	2			
Or	Orange	3			
Your	Yellow	4			
Great	Green	5			
Big	Blue	6			
Venture	Violet	7			
Goes	Grey	8			
West	White	9			
	Silver	0.01	10%		
	Gold	0.1	5%		

Higher precision resistors will have other tolerance colours, not shown. Some very high precision resistors will have five bands, three for value, one for multiplier, and one for tolerance.

## OHM'S LAW (CH 3)

1. R = Resistance (ohms)
2. E = Energy (volts)
3. I = Current (amperes)
4. P = Power (watts)
5. If E through a circuit is doubled, P increases 4x, because E and I both double. (Try it. Take any E and I, and calculate R {E / I}. Then calculate P {E \* I}. Now, double E. Recalculate I, keeping R the same. Take E \* I to get P. It will increase by 4x.)

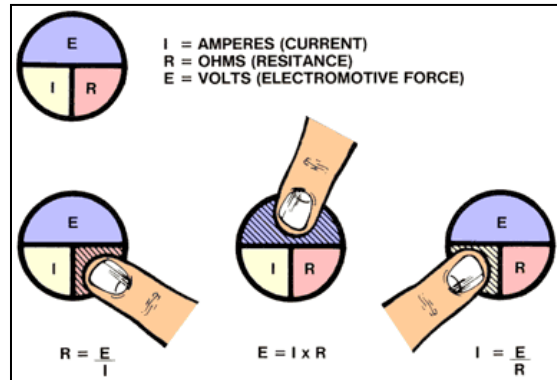

6.  $E = I * R$ ,  $I = E / R$ ,  $R = E / I$
7.  $P = E * I$
8. Voltage drop = voltage developed across terminals of a component. (Ch2)
9. Resistors:
  - a. Current and resistance are inversely proportional.
  - b. Voltage drop and resistance are proportional.
10. Parallel resistors:
  - a. Current is sum of current through each resistor.
  - b. Voltage drop is the same at each resistor.
  - c. Total Resistance is less than the smallest Resistor.
  - d. In equal resistors, total wattage is the sum of the wattage of each resistor.
  - e. For equal value resistors,  $R_t = R / x$ ,  
Where x = the number of resistors.
11. Series resistors:
  - a. Current is the same at any point in the circuit.
  - b. Voltage drop is different at each resistor.
  - c. Total resistance is greater than any one resistor.
  - d. In equal resistors, total wattage is equal to the sum of the wattage of each resistor.
  - e.  $R_t = R_1 + R_2 + R_3 + R_4...$

### Current from Power and Resistance?

Question B-005-06-07 reads: "If the power is 500 watts and the resistance is 20 ohms, the current is \_? It's a head-scratcher, isn't it. But take it step by step, and it comes together.

1. We know  $P = 500$  and  $R = 20$ .  $P = E * I$ . We don't know E and we want to know I.
2. How do we get E?  $E = I * R$ . So  $P = I * R * I$ , or  $P = I^2 * R$ .
3. Inserting the numbers we get:  $500 = I^2 * 20$ , or  $I^2 = 500 / 20$ .  
(By convention, the unknown value goes on the left, so I reversed the equation.)
4.  $I^2 = 500 / 20$ . So  $I^2 = 25$ .
5. Finally,  $I = \sqrt{25}$ , or  $I = 5$ . **The current is 5 amps.**

---

A PARALLEL EXAMPLE:

---

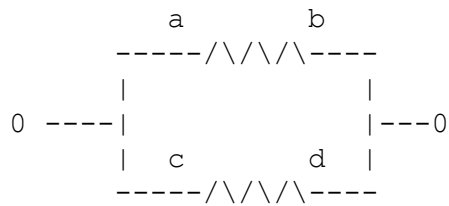

Let's assume  $R_1 = 100$  ohms and  $R_2 = 200$  ohms.

Let's assume  $E = 10$  v

We know the total voltage drop to be 10 volts.

We know that the voltage drop across each resistor is the same, because measuring the voltage at a/b is exactly the same as measuring it across c/d.

1. We can calculate  $R_t = \frac{R_1 \times R_2}{R_1 + R_2}$   
 $(100 \times 200) / (100 + 200) = 66.67$  ohms.
2. What is the current (I) across  $R_1$ ?  
 $I_1 = E / R_1 = 10 / 100 = 0.1$  amps.
3. What is the current (I) across  $R_2$ ?  
 $I_2 = E / R_2 = 10 / 200 = 0.05$  amps.
4.  $I_t = 0.1 + 0.05 = 0.15$  amps.
5. How much power is this circuit dissipating?  
 $P = E * I$   
 $P = 10 * 0.15 = 1.5$  watts
6. Power dissipation at  $R_1$ :  $P = E * I_1$   
 $P_1 = 10 * 0.1 = 1$  watt
7. Power dissipation at  $R_2$ :  $P = E * I_2$   
 $P_2 = 10 * 0.05 = 0.5$  watts

---

### A SERIES EXAMPLE:

---

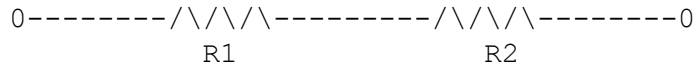

Let's assume  $R_1 = 100$  ohms and  $R_2 = 200$  ohms.

Let's assume  $E = 10$  v

1. We know the total voltage drop to be 10 volts.  
We can calculate  $R_t = R_1 + R_2 = 300$  ohms  
We can now calculate  $I = E / R = 10 / 300 = 0.033$  amps
2. What is the voltage drop across  $R_1$ ?  
 $E_1 = I * R_1 = 0.033 * 100 = 3.3$  volts.
3. What is the voltage drop across  $R_2$ ?  
 $E_2 = I * R_2 = 0.033 * 200 = 6.6$  volts.
4.  $6.6 + 3.3 = 10$  volts, proving that the voltage drop across all components equals the total voltage drop in the circuit.
5. How much power is this circuit dissipating?  
 $P = E * I = 10 * 0.033 = 0.33$  watts.
6. Power dissipation at  $R_1$ :  $P = E_1 * I$   
 $P_1 = 3.3 * 0.033 = 0.109$  watts
7. Power dissipation at  $R_2$ :  $P = E_2 * I$   
 $P_2 = 6.6 * 0.033 = 0.212$  watts

## INDUCTORS AND CAPACITORS (CH 4)

---

1. Parallel and series inductance is calculated like resistance.
2. Parallel and series capacitance is calculated opposite to resistance.
3. Inductance:
  - a. Symbol = L, unit = Henries.
  - b. L is a function of core material, core diameter, length of coil, number of turns of wire (not total length of wire).
  - c. Inductance refers only to the physical properties of a coil.
4. Capacitance:
  - a. Symbol = C, unit = Farads.
  - b. C is a function of the material between the plates (dielectric), the area of one side of one plate, the number of plates, and the plate spacing.
  - c. Capacitance refers only to the physical properties of the device.
5. Reactance:
  - a. Reactance refers to the effect of an alternating current on an inductor or a capacitor.
  - b. Symbol =  $X_L$  or  $X_C$ , unit = ohms.
  - c. As frequency increases, inductive reactance increases.
    - i. In other words, a coil is resistance to A/C current.
  - d. As frequency increases, capacitive reactance decreases.
    - i. In other words, a capacitor is resistance to D/C current.
  - e.  $X_C = 1 / (2\pi f C)$
  - f.  $X_L = 2\pi f L$

### Why two pi?

A sine wave is a circular function. If you had a generator with two poles and you turned it to create an A/C current, you would create a sine wave. Frequency is a measure of how many times that wave passes a given point in a period of time. The perimeter of a circle is  $2\pi$  times its radius. So, by adding  $2\pi$  to the equation, we are converting the frequency to a circular function representing the rotation required to create that wave. In some references,  $2\pi$  is represented by the symbol  $\omega$ .

6. Impedance:
  - a. Impedance is the combined effect of reactance and pure resistance.
  - b. Symbol Z, unit = ohms.
7. Resonant Frequency
  - a. At the resonant frequency, inductive reactance and capacitive reactance are equal. (This is a tuned circuit.)
    - i. In a parallel circuit, impedance is high at resonance.
    - ii. In a series circuit, impedance is low at resonance.
  - b. Adding a resistor to an LC circuit does not affect the resonant frequency.
8. Magnetism:
  - a. Like poles repel each other.
  - b. Permanent magnets are typically made of steel.

9. Transformers:

- a. The strength of a magnetic field around a conductor is directly proportional to the current flow.
- b. Voltage is induced when current flow changes.
- c. Maximum voltage is induced when the magnetic field is perpendicular
- d. Transformers get warm, demonstrating they are not 100% efficient.
- e. Transformers follow ohms law. The total power consumed by the primary is equal to the power consumed by the secondary (not including losses to heat).
  - i. Therefore:  $E_p * I_p = E_s * I_s$
  - ii. So, if E is decreased (step-down transformer) I must increase.
- f. Turns Ratio:  $E_s / E_p = N_s / N_p$ , where E = voltage and N = # turns.
- g. Magnetizing current flows in the primary winding when no load is attached.

## WAVES, WAVELENGTH, FREQUENCY AND BANDS (CH 5)

---

1. The bandwidth of a station is measured at the frequency that is 26 dB below the maximum amplitude of the signal.
2. **Frequency** is the number of times per second that an Alternating current flows back and forth.
3. **Wavelength** is the distance an A/C signal travels in one cycle.
4. Hz (**Hertz**) = cycles per second.
5.  $1 / \text{frequency} = \text{period}$  (length of time for one cycle).
6.  $1 / \text{period} = \text{frequency}$ .
7. As wavelength increases, frequency decreases.
8. Most humans can hear from 20 to 20,000 Hz (**audio frequencies**).
9. Frequencies above 20 KHz are **Radio Frequencies**.
10. A **harmonic** is a whole number fraction or multiple of the operating frequency.

---

### AMATEUR RADIO HF / VHF BANDS

---

Band	Frequency (MHz)		Bandwidth (KHz)	License	Range	Freq. Range (KHz)
	From	To				
<b>160 metres</b>	1.800	2.000	6	B+H / B+A	MF	200
<b>80 metres</b>	3.500	4.000	6	B+H / B+A	HF	500
<b>40 metres</b>	7.000	7.300	6	B+H / B+A		300
<b>30 metres</b>	10.100	10.150	1	B+H / B+A		50
<b>20 metres</b>	14.000	14.350	6	B+H / B+A		350
<b>17 metres</b>	18.068	18.168	6	B+H / B+A		100
<b>15 metres</b>	21.000	21.450	6	B+H / B+A		450
<b>12 metres</b>	24.890	24.990	6	B+H / B+A		100
<b>10 metres</b>	28.000	29.700	20	B+H / B+A*		1,700
<b>6 metres</b>	50.000	54.000	30	B		VHF
<b>2 metres</b>	144.000	148.000	30	B	4,000	
<b>1.5 metres</b>	222.000	225.000	100	B	3,000	
<b>70 cm</b>	430.000	450.000	12,000	B	UHF	20,000
* A holder of a Basic License may operate a repeater with an output frequency between 29.5 MHz and 30 MHz.						

---

**AMATEUR RADIO EMISSION MODES**

---

<b>Mode</b>	<b>Bandwidth (approx)</b>	<b>Description</b>	<b>Type</b>
CW	500 Hz	Morse code (Continuous Wave)	Manual
SSB	3 KHz	Suppressed-carrier single sideband	Voice
AM	6 KHz	Amplitude Modulation	
FM	10 KHz	Frequency Modulation	
AMTOR	600 Hz	Amateur Teleprinting over Radio	Digital
Packet	10+ KHz	Packet	
FSTV	4 MHz	Fast-scan TV	
SSTV	3 KHz	Slow-scan TV	

## PROPAGATION (CH 6)

---

### MISCELLANEOUS

---

1. **Line-of-sight** propagation or **direct wave** is straight-line between two radios.
  - a. Most common on VHF+
  - a. Most common between handheld radios (also called HTs, from “handie talkie)
2. **Ground wave** propagation travels along the surface of the Earth.
  - a. At VHF frequencies, line-of-sight uses ground wave over short distances.
  - b. At MF frequencies, ground wave may travel 200 km.
3. **Skywave** propagation or **ionospheric wave** is propagated skyward to the ionosphere (and back).
  - a. It is longer than ground-wave.
  - b. It operates at HF frequencies.
4. **Multihop** is when a signal reflects more than once.
5. **Skip Zone** is the area beyond ground wave and too close for sky wave propagation.
  - a. It is determined by the height of the ionosphere and the angle of radiation.
  - b. Skip distance is the minimum distance reached by an ionospheric reflection.
  - c. *B-007-08-01*, which has you use ground wave within the skip zone is not entirely correct.
6. **Fading** or **selective fading** occurs when two or more parts of the signal follow different paths or different numbers of hops.
  - a. This results in a fluctuating signal strength caused by phase differences.
  - b. Wider bandwidths are more affected by selective fading.
7. **Antenna polarization** is less important on HF because the ionosphere can continually change polarization.
  - a. Polarization changes may be caused by reflections, refractions, or faraday rotation.
8. **Phase-shift distortion** is the variation in *phase*, or shape of the waveform. SSB and AM are not affected by this.
9. **Tropospheric ducting**, caused by temperature inversions, can extend VHF signals to 800 kilometres.
10. **Scatter** occurs due to clumps of highly ionized air and results in propagation *of a part of the signal* within the skip zone.
  - a. It occurs near or above the MUF, mainly 30 - 100 MHz (with 6 metres {50MHz} being the sweet-spot).
  - b. It results in the signal taking multiple paths.
  - c. It results in weak, fading signals (wavering).
  - d. There is meteor scatter, Tropospheric scatter and ionospheric scatter.
  - d. There is back scatter, side scatter, forward scatter.

---

### SUNSPOTS AND SOLAR ACTIVITY

---

11. **Sunspots** greatly affect atmospheric ionization, and therefore affects all propagation beyond line-of-sight (and all RF communications to some extent).
  - a. More sunspots = more ionization.
  - b. Sunspot cycle is 11 years. (Actually, it can vary from 9 to 14 years.)
  - c. Sunspots emit electromagnetic and particle emissions.

- d. When sunspot activity is high, maximum useable frequency (MUF) can exceed 40 MHz.
  - e. 20/30 metres are always "open".
  - f. 40/80/160 metres work poorly during the day, the summer, or during sunspot peaks, due to absorption.
12. Signals higher than the **critical frequency** pass through the ionosphere.
  13. Signals at or lower than the **maximum useable frequency** (MUF) reflect back to earth.
    - a. MUF is affected by solar radiation.
    - b. Beacon stations can help us determine MUF.  
(See [http://en.wikipedia.org/wiki/Radio\\_propagation\\_beacon](http://en.wikipedia.org/wiki/Radio_propagation_beacon))
    - c. The **optimum workable frequency** is just below the MUF.
  14. **Solar Flux** is the radio energy emitted by the sun.
    - a. **Solar flux index** is a measure of solar activity taken at a specific benchmark frequency.

---

## IONOSPHERE

---

15. The **ionosphere** is caused by solar radiation (*B-007-02-01 is wrong.*)
  - a. UV radiation mainly.
  - b. Strongest ionization at mid-day, weakest just before dawn.
  - c. Starting closest to Earth, the layers are D E F1 and F2.
  - d. Higher layers = longer propagation.
16. **D Layer:**
  - a. D Layer absorbs low-frequencies.
  - b. It depletes at night, allowing DX on 40, 80, 160 metres.
17. **E Layer:**
  - a. E Layer propagation = 2000 km
  - b. **Sporadic E** is caused by dense regions in the E Layer.
  - c. The 6 metre band uses the E Layer mainly (sporadic E).
  - d. **Auroral propagation** occurs mainly in the E Layer, due to reflection off of Northern Lights over the North Pole.
    - i. Narrow-band modes (CW & SSB) are most effective here due to selective fading.
18. **F Layer:**
  - a. F1 and F2 merge at night into one layer.
  - b. F2 is the least-useful layer for DX.
  - c. F2 propagation = 4500 km
19. **Ionospheric storms** are caused by **solar coronal mass ejections** (CMEs) and **solar flares**, which massively charge the ionosphere, causing sky wave signals to fade-out.
  - a. Lower frequencies will be absorbed.
  - b. Satellites and electrical power grids are also negatively affected.
  - c. For unknown reasons, solar storms are most frequent during declining sunspot numbers.

## TRANSMISSION LINES (CH 7)

---

1. Transmission line = **feedline**.
2. **Parallel wire** line consists of two parallel wires separated by a fixed distance.
  - a. Benefits of parallel wire line: It can easily be home-brewed, and works very well with a high VSWR.
  - b. Disadvantages of parallel wire line: It does not work well near metal objects, and must be impedance matched to most transceivers.
  - c. Open wire, a type of parallel wire line, has the lowest line loss.
3. **Coaxial cable** consists of a centre wire inside an insulating material, covered by a metal sleeve or shield.
  - a. Benefits of coax: it is weatherproof, its impedance matches most amateur equipment, and it can be used near metal objects or (usually) underground.
  - b. Disadvantages of coax: It cannot be home-brewed, it has higher loss than parallel wire line, and works poorly at high VSWR.
4. **Line losses (coaxial cable):**
  - a. Line loss increases with frequency.
  - b. Line loss increases with cable length. Doubling the length will double the loss.
  - c. Line loss (measured as dB/100') results in less radiated signal.
5. **Coax types:**
  - a. **RG213** is a common and reasonably effective type of coaxial cable, about ½" in diameter.
    - i. **9913** and **LMR400** are the same size, but lower loss.
    - ii. **RG8** is similar to RG213, with slightly higher loss.
  - b. **RG58** is quite small, and used for low-power applications.
    - i. **RG59** is like RG58, but has an impedance of 75 ohms. It is used for cable TV.
    - ii. **RG174** is also small, and is not waterproof.
6. **Connectors:**
  - a. A **PL-259**, or UHF connector typically terminates larger cables like RG213. (Note: UHF in this case means "union – high frequency" not "ultra-high frequency".)
    - i. PL-259 is only effective up to VHF frequencies, as it has an impedance of 35 (not 50) ohms.
    - ii. The female side of this connector is generally on the chassis, and is an **SO-239**.
  - b. **BNC** is a smaller barrel-type connector, effective up to UHF frequencies.
  - c. **SMA** is a smaller threaded connector, also effective to UHF frequencies.
  - d. **N** is a larger waterproof connector, most used on commercial applications and repeaters, and effective into the GHz frequencies.
  - e. Antenna connectors should be periodically cleaned, tightened and re-soldered to keep their resistance at a minimum.
7. The **characteristic impedance** of a transmission line is equal to the pure resistance which, if connected to the end of the line, would absorb all of the power arriving along it (resulting in a VSWR of 1:1).
  - a. Therefore, any length of feedline may be made to appear infinitely long, by terminating it at its characteristic impedance.

- b. **Characteristic impedance of parallel wire line** depends on the radius of the conductors, and the centre-to-centre distance of the conductors.
  - c. **Characteristic impedance of coaxial cable** depends on the ratio of the diameter of the inner conductor to the diameter of the braid.
- 8. Transmission lines experience **propagation delay**, which is quantified as the **velocity factor**. It is due to the fact that the signal travels much slower than the speed of light in the feedline.
- 9. **A balun** (balanced to unbalanced) changes a balanced signal, as from a dipole antenna, to an unbalanced signal, as for a coaxial cable.
  - a. A balun is typically installed between the coax and the antenna.
  - b. In an unbalanced line, one conductor (the shield) is connected to ground.
  - c. In a balanced antenna (like a dipole), neither end is grounded.
  - d. A balun (or impedance matching device) may also be used to match impedances.
    - i. A 4:1 balun would match a 75 ohm feedline to a 300 ohm antenna.
- 10. **SWR or VSWR:**
  - a. Stands for Voltage Standing Wave Ratio, which compares forward and reflected voltages.
    - i. If antenna impedance = 200 ohms and feedline impedance = 50 ohms, SWR = 4:1
  - b. An SWR of 1:1 is a perfect impedance match.
    - i. At this SWR, maximum power is delivered to the load.
    - ii. An SWR of 1.5:1 is a reasonable impedance match.
  - c. A jumpy reading may indicate a poor electrical connection.
  - d. A very high SWR could be due to an antenna of the wrong length, or an open or shorted connection.
  - e. Where there is an impedance mismatch (high VSWR), standing waves are produced in the feedline, and RF energy to the antenna is reduced.
  - f. A hot feedline indicates a poor (high) VSWR.
  - g. A high impedance feedline is most effective for handling high SWR. (High impedance = low current, therefore less heat loss.)
  - h. An antenna tuner (or antenna matching unit) changes the impedance (using variable capacitors and inductors) to match an antenna to the feedline and radio.
  - i. Feedline length has no impact on impedance or SWR.

## ANTENNAS (CH 8)

---

1. Antennas may be **balanced** (centre-fed) or **unbalanced** (one side is grounded).
  - a. Ladderline is balanced, coaxial cable is unbalanced, because the shield is grounded.
  - b. A balun will allow an unbalanced feedline (coaxial) to connect properly to a balanced antenna (dipole).
2. At its **resonant frequency**, an antenna supports a standing wave of the radiated frequency exactly within its length.
  - a. A shorter antenna will resonate at a shorter wavelength, which is a higher frequency.
  - b. A longer antenna will resonate at a longer wavelength, which is a lower frequency.
  - c. At resonance, an antenna will have a characteristic feedpoint impedance, which may or may not be  $50\Omega$ .
3. All antenna characteristics affect receive and transmit qualities equally.
4. RF energy travels 300 000 km/sec, (the speed of light) therefore:
  - a. Frequency =  $300 / \text{wavelength}$
  - b. Wavelength =  $300 / \text{frequency}$
5. An **Isotropic Antenna** is a hypothetical point-source antenna against which real antennas are measured.
  - a. Its radiation pattern is a sphere.
  - b. A half-wave dipole will have about 2.1dB gain over an isotropic antenna.
  - c. Gain references to an isotropic antenna are in dBi.
  - d. Gain references to a dipole antenna are in dBd.
6. A **half-wave dipole** is a centre-fed antenna a half-wavelength long.
  - a. Its pattern is broadside, with minimum radiation off the ends<sup>1</sup>.
  - b. A horizontal dipole has a pattern that looks like a figure-eight (when viewed from above), perpendicular to the antenna.
  - c. The characteristic impedance of a dipole is 73 ohms.
7. A **folded dipole** is one wavelength long, but folded back on itself.
  - a. The characteristic impedance of a folded dipole is 300 ohms.
  - b. It has greater bandwidth than a half-wave dipole, making it effective for commercial antennas.

---

<sup>1</sup> This only applies where the dipole is more than a quarter wavelength above ground. Below that, the pattern is nearly omnidirectional, with the takeoff angle around 70 degrees.

8. The basic structure of a beam, or **Yagi-Uda** antenna:

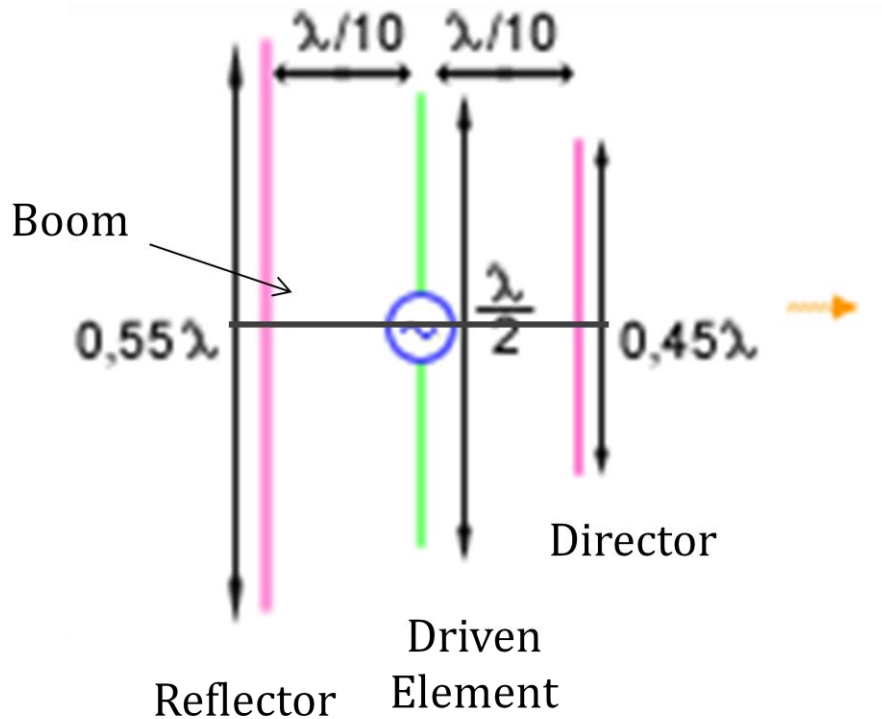

- a. Radiation is towards the Director, with little transmission or reception off the side, reducing interference from the side.
  - b. A Yagi-Uda antenna is also called a parasitic beam antenna, as the other elements get their energy parasitically (not directly) from the driven element.
  - c. Larger diameter elements will increase the bandwidth of a beam (or any) antenna.
  - d. Lobes are generated towards the shorter (director) elements and away from the longer (reflector) element.
  - e. Wider element spacing results in higher gain, less critical tuning (lower Q) and wider bandwidth.  $1/5$  wavelength (0.20) element separation is optimal for this.
    - i. Element spacing of  $1/10$  wavelength (0.10) gives lower Q, but higher gain.
  - f. Stacking two Yagi antennas increases the gain by 3 dB
9. A **vertical antenna** has a vertical radiating element either  $1/4$ ,  $1/2$  or  $5/8$  wavelengths long.
- a. Also called a **whip antenna**.
  - b. It's pattern is circular, along the horizontal plane.
  - c. A  $5/8$  wave has more gain than a  $1/2$  wave for mobile operation, as the primary lobe is more horizontal.
  - d.  $1/4$  and  $5/8$  wave verticals (being unbalanced and not a half-wavelength) require a ground plane.
    - i. This could be the roof of a car.
    - ii. This could be air radials, or wires at the base of the antenna.
    - iii. These radials slope down at  $45^\circ$  to raise the feedpoint impedance to  $50\Omega$ .
    - iv.  $50\Omega$  coax gives the best impedance match.
10. A **random wire antenna** is just that, a random length of wire directly connected to the radio.
- a. It is often used for receive-only, as it is not tuned.

- b. It may be operated on transmit through a tuner.
  - c. Disadvantage: It will allow RF into the station, as it is usually directly connected.
11. A **cubical quad antenna** is two or more four-sided wire loops, each roughly one wavelength long.
- a. The side of the antenna with the feedpoint determines its polarization.
  - b. Because it narrows the beam both vertically and horizontally, a two element quad has the same gain as a three element beam.
  - c. A **delta loop** is like a cubical quad, but triangular.
12. Antenna element lengths:
- a. Dipole or Beam Driven Element =  $\frac{1}{2}$  wavelength \* 0.95. ( $150 / f * 0.95$ )
  - b. Cubicle Quad Driven Element = 1.02 wavelengths. ( $300 / f * 1.02$ )
  - c. Reflector = DE + 5%.
  - d. Director = DE – 5%
  - e. Quarter-wave vertical =  $\frac{1}{4}$  wavelength \* .95 ( $71.5 / f$ )
  - f. Half-wave vertical =  $\frac{1}{2}$  wavelength \* .95 ( $150 / f * 0.95$ )
13. Polarization:
- a. **Polarization** refers to the orientation of the electric lines of force.
  - b. A **vertically polarized** antenna is oriented with the electric lines of force perpendicular to the Earth's surface.
  - c. A **horizontally polarized** antenna is oriented with the electric lines of force parallel to the Earth's surface.
  - d. The orientation of the driven section of an antenna is its polarization.
  - e. With line-of-sight signals, the transmitting and receiving antennas should have the same polarization.
14. Adding a **series inductance** (loading coil) to an antenna will decrease its resonant frequency, allowing the antenna to be shorter and still resonate.
- a. These are often used on HF mobile verticals to shorten them.
15. Horizontal wire antennas should be terminated with insulators, which limit the electrical length of the antenna.
16. "Traps" in a **trap dipole** are coils and capacitors in parallel, which create a multi-band antenna.
- a. Antennas with traps tend to radiate harmonics.
17. **Bandwidth** refers to the range of frequencies to which it will tune.
18. **Antenna gain** refers to the ratio between the radiated signal strength of an antenna (in a particular direction) against a benchmark antenna (either an isotropic radiator or a dipole).
19. **Front-to-back ratio** refers to the ratio of the maximum forward power to the maximum backward power of a beam antenna.

1. **Amplifiers:**

- a. An **amplifier** increases the level of its input signal.
  - i. An amplifier may increase voltage, current or power, but not resistance.
  - ii. This increase in signal level is galled **gain**, and is measured in decibels (dB).
- b. **Linearity** refers to the fidelity of the output signal compared to the input.
  - i. If an amplifier becomes **non-linear**, its output signal is **distorted**.
- c. An **RF amplifier** can be used to amplify very weak radio signals from an antenna.
  - i. We often call such an amplifier a pre-amp.
  - ii. We often call the RF amplifier at the output end the PA, or Power Amplifier.
- d. An **audio amplifier** increases the level of weak audio signals.
  - i. A **speech amplifier** (not music) covers 300 – 3400 Hz.

2. **Diodes:**

- a. A diode allows current to pass in one direction, but not the other.
  - i. It conducts when **forward-biased**.
- b. Its electrodes are called the **anode** and **cathode**.
  - i. Electrons travel from **cathode** to **anode**. (A to C in conventional current.)
- c. Diodes are used to change alternating current into direct current, called “**rectification**.”
  - i. They create **pulsating direct current**, which is smoothed with capacitors.
- d. Diodes are also used to recover information from RF signals, called “**demodulation**.”
- e. When reversed-biased, a **zener diode** acts as a voltage regulator by creating a specific voltage drop at its breakdown voltage, regardless of current.
- f. A **light-emitting diode** (LED) glows when forward-biased.

3. **Transistors:**

- a. **Bipolar Transistors** (whether PNP or NPN) can **amplify** small signals using low voltages.
  - i. They are the basic semi-conductor amplifying device.
- b. The three leads are named: **Base**, **Collector** and **Emitter**.
- c. The two basic types are **NPN** and **PNP**.
- d. Excessive heat can destroy a transistor.

4. **Pin Comparisons**

Transistor	Diode	FET	Tube	Function*
Base		Gate	Grid	Control
Collector	Anode	Drain	Anode (Plate)	Destination
Emitter	Cathode	Source	Cathode	Source
The FET description is in terms of real electron flow, while the others are based on conventional current flow.				

## 5. Field Effect Transistors (FET):

- a. The two basic types are **P channel** and **N channel**.
- b. Electrons flow from the **source** to the **drain**, modulated by the **gate**.
  - i. In theory, source and drain can be reversed.
- c. Reverse-biasing the channel reduces current-flow through the FET.

## 6. Vacuum Tubes:

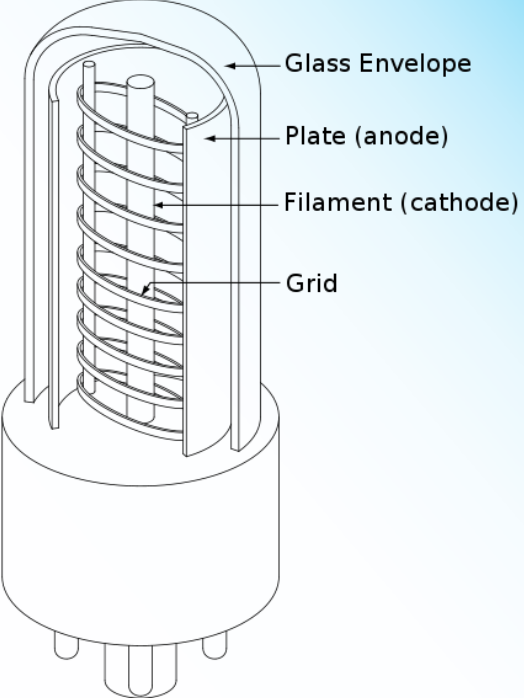
 <p>Source: en.wikipedia.org</p>	<p><b>How Tubes Work:</b></p> <p><b>Diode</b></p> <ol style="list-style-type: none"><li>1. The <b>cathode</b> releases electrons into the vacuum (space charge).</li><li>2. When the <b>anode</b> (plate) is positively charged relative to the filament (<b>cathode</b>), electricity will flow.</li></ol> <p><b>Triode</b></p> <ol style="list-style-type: none"><li>3. When a <b>grid</b> is introduced, you have a triode, which (like a FET) regulates current flow.</li><li>4. The grid has DC bias voltage.</li><li>5. The more negative the DC bias voltage, the less current flows from Cathode to Anode.</li></ol> <p><i>The cathode must be hot, and the anode cold (relatively). This makes them inefficient, and prone to failure.</i></p>
--	---

- a. Tubes are still used as less expensive options for **high power** applications.
- b. Tubes can **amplify** small signals, but require **high voltage** to operate.
- c. There is a **vacuum** inside the glass (or ceramic) envelope of the tube.
- d. **Diode vacuum tubes** act like semiconductor diodes.
  - i. The **cathode** emits negative electrons into the vacuum.
  - ii. The **plate (anode)** has a high positive voltage.
  - iii. When **forward-biased**, current (electrons) travels from the cathode to the anode.
- e. A **triode vacuum tube** is most like a Field Effect Transistor (FET).
  - i. It has the diode components (**anode & cathode**) plus a **grid**.
  - ii. The **control grid** encircles the cathode and controls the flow of electrons.
    1. When the grid is positive relative to the cathode, electron-flow is restricted. This can be controlled, and is called **bias voltage**.
    2. When the grid is not charged, electrons will flow freely.

- iii. The negative DC control voltage applied to the grid is called the **bias voltage**.
- f. The **cathode is heated**. (That's how it emits electrons.)
  - i. The cathode may be heated directly, or indirectly using a separate heater.
  - ii. To maintain a temperature difference between the cathode and the plate (anode), the plate is the farthest element from the heater.

## POWER SUPPLIES (CH 10)

- Generally, we require a **power supply** to:
  - Lower the line voltage to (roughly) 12 volts.
  - Change the voltage from AC to DC.
- Since we are lowering the voltage, we must increase the current (amperage) to produce the same amount of power.
  - $P = E * I$ , so 50 watts @ 120 volts = 0.42 amps, but 50 watts @ 12 volts = 4.2 amps.
  - More current requires larger diameter wire.
- Regulated power supply** block diagram:

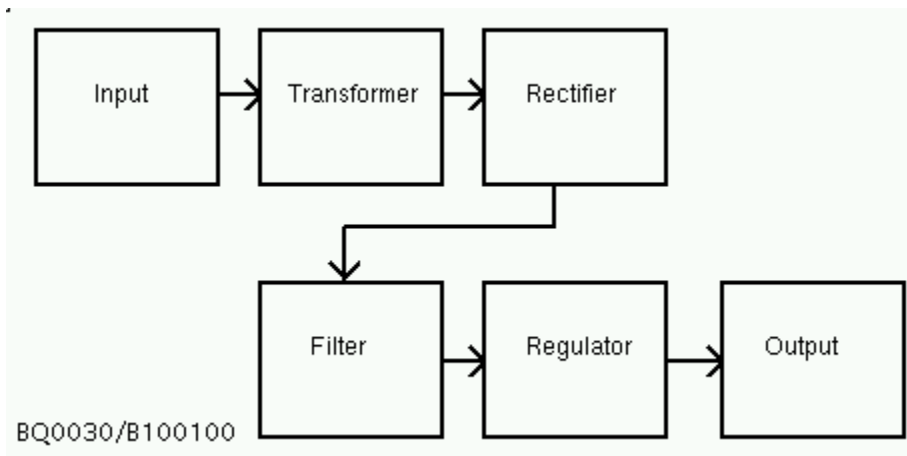

- Input** is generally AC line voltage, which is standardized to 120 volts and 240 volts.
- Transformer** steps the voltage down from 120 volts to 12 volts<sup>2</sup>.

- The transformer must be rated at a wattage greater than the produced  $E * I$ .

- Rectifier** (or diode) converts AC to DC, as it only passes electrons in one direction.

- The rectifier section will create rippled or pulsating DC.

**A** is the input signal.

**B** is half-wave rectification from a single diode.

**C** is full-wave rectification from multiple diodes.

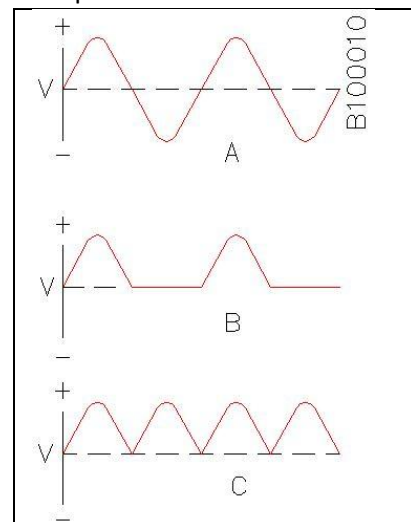

- The **filter** section removes ripples from the rectified signal.
  - Poor filtering can create a hum or buzzing in the connected equipment.

<sup>2</sup> A fully charged car battery is actually closer to 13.8 volts. Amateur radios generally operate from 12 to 13.8 volts DC, with power supplies producing 13.8 volts. However, the exam uses 12 volts throughout.

8. **Regulator** maintains a constant voltage output regardless of the current flow.
9. **Output** connects to your equipment.
10. **Transformerless power supplies** are used in tube-type radios and TV receivers.
  - a. They can be dangerous, as one side of the line cord is connected to the chassis.
  - b. An **autotransformer** can be used where your household voltages are consistently high or low.

An autotransformer is not an automatic, or regulating, transformer. "Auto" refers to the fact that it has a single, tapped winding. If it is tapped in the middle of the winding, the output voltage will be one-half the input voltage. Because an autotransformer has a single winding, it provides no electrical isolation, and is therefore somewhat dangerous.

11. A **multimeter** generally measures voltage, current and resistance (and often more).
12. **Voltmeters** are connected to a test circuit in **parallel** (across the contact points) to measure **potential difference**.
  - a. AC voltage is measured as RMS voltage, which is an average over time.

RMS voltage is actually the square root of the square of the instantaneous voltages over time, and is used to average varying quantities, especially where some values are negative numbers. It works out to 0.707 x the peak voltage.

- b. Voltmeters have a very high impedance (resistance) to minimize their impact on the circuit under test.
  - c. **Voltage drop** is the voltage between two terminals of a component. (Think of it as the amount of energy lost through that component.)
13. **Ammeters**, which measure current, are connected to a test circuit in **series** (in-line with the circuit).
  - a. Both AC and DC current may be measured.
  - b. Ammeters have a very low impedance to minimize their impact on the circuit.

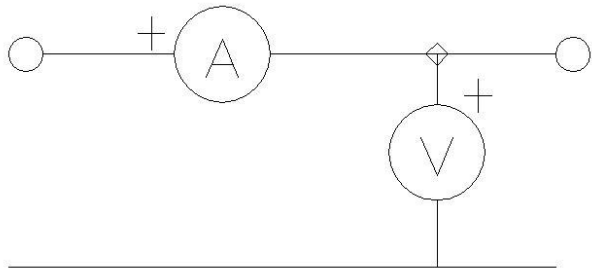

B100070

**Ammeters** are connected in-line (series) with your circuit. This requires removing a wire from the circuit and connecting the meter so all the current travels through the meter and back to the circuit. For this reason, ammeters must be low-impedance to minimize their effect on the circuit.

**Voltmeters** are connected in parallel with the circuit, and so may simply be connected across the desired component leads. To minimize their effect on the circuit, voltmeters have high impedance, at least 1 Meg-ohm.

## ESTABLISHING AND EQUIPPING AN AMATEUR STATION (CH 11)

1. **Low-pass filters** will pass low frequencies and cut-off high frequencies.
  - a. They reduce **harmonic radiation**, which is RF radiation at multiple frequencies of the desired frequency.
  - b. A low-pass filter of, say, 30 MHz on an HF station will pass all HF signals to the antenna, and cut-off higher-frequency emissions, reducing interference to nearby TVs and radios.
  - c. They are generally connected **close to the radio or linear amplifier**, as they are filtering signals emanating from (not travelling to) the equipment.
2. **SWR bridge**, or SWR meter measures the forward and reflected power to your antenna.
  - a. It is the most effective measure of your antenna system.
3. Typical component arrangement:

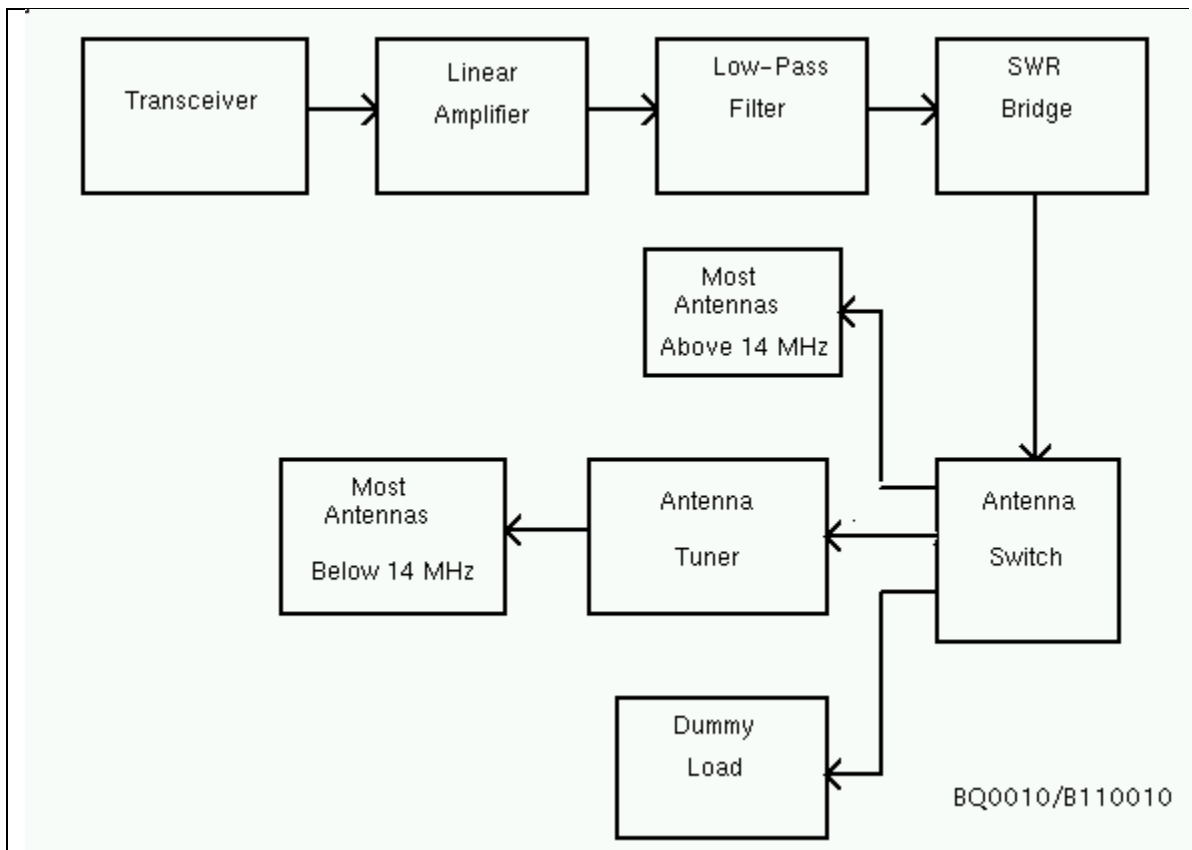

4. **Antenna tuners** match the impedance between the radio and the antenna system.
  - a. They are most-often used at frequencies below 14 MHz (20 metre band).
  - b. They may be manual or automatic, and may be built-in to the radio, or outboard.
5. A **dummy load** or **dummy antenna** is a 50 ohm resistive load capable of accepting high power.
  - a. It is used to **tune equipment**, especially linear amplifiers, without unnecessarily radiating through an antenna.
  - b. Because it changes RF energy into heat (instead of radiated energy) it gets hot.

6. In **digital systems** the input/output is controlled by a computer.

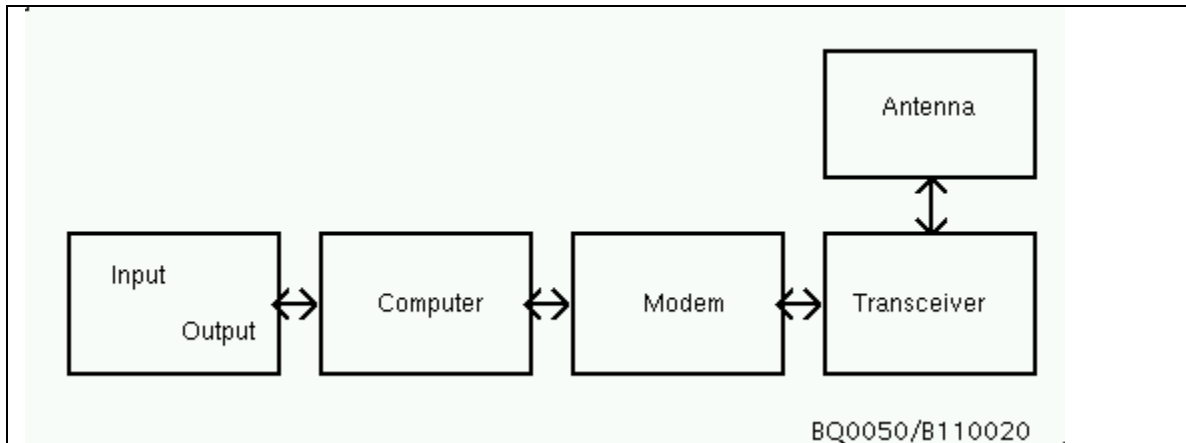

7. **Morse Code**, or CW, is the original digital mode. <- pun, get it!
- Electronic keyers** help to form proper CW characters.
8. **Voice** or **phone** operation is achieved by connecting a microphone to the transceiver.
- VOX** circuits cause the radio to transmit automatically when the operator speaks, without pushing the PTT button.
  - Speech processors** can alter the bass/treble of your voice and also compress it to improve intelligibility (but not necessarily fidelity) at the receiving-end.
    - The compression brings your SSB modulation closer to 100%, so if it is already near 100%, the speech process will add nothing to the output PEP.<sup>3</sup>
9. **Microphones** can be crystal, dynamic, condenser or carbon.
- A **dynamic microphone** works on the principle that a moving coil around a magnet produces electrical current. A speaker could be used as a dynamic mic.
10. Some systems employ **separate receive and transmit antennas**.
- When switching from receive to transmit, the **receiver is muted**.
  - Antenna changeover switches** accomplish this, and will generally disable the antenna not in use.
11. **Packet Radio** is a digital mode where messages are sent in digital packets (generally on VHF).
- Packet uses AX.25 protocol (not baudot) to send ASCII characters.
  - At VHF frequencies, data rate is generally 1200 baud.
  - Connected** means that two radios are communicating only with each other, with each station acknowledging ("ack") correctly received packets to the other.
  - Monitoring** means a station is displaying messages not sent to it, and not replying (or "ack-ing") to those message.
  - Networks** are means of connecting many radios to allow data to be sent over long distances.
  - The **Terminal Node Controller (TNC)** is like a modem, and connects between the computer and the radio through a radio's microphone input and speaker output.
12. **RTTY** (Radio Teletype) is a digital mode used over HF.

<sup>3</sup> More on this in chapter 13.

- a. Signals called **mark** and **space** are used to represent digital ones and zeroes.
  - b. RTTY uses the Baudot encoding method, which is seven-bit. Therefore all characters are upper-case
  - c. Minimum **frequency separation** between nearby contacts should be 250-500 Hz.
13. **AMTOR** is an updated protocol from RTTY with some advantages.
- a. It uses an eight-bit encoding scheme allowing upper and lower-case text.
  - b. It uses two modes:
    - i. **A mode** (ARQ, or Acknowledgment Request) is used when two stations are connected. "Acks" are sent to confirm receipt of data, ensuring it is error-free.
    - ii. **B mode** (FEC, or Forward-error correction) for broadcast messages. To reduce errors, each character is sent twice.
14. A **digipeater** (or digital repeater) that retransmits data marked to be re-transmitted.
- a. Digipeaters do not operate in real-time like audio repeaters, but store the packet, and re-send it, often after altering the packet's path information. Digipeaters are therefore much simpler to build. (This is called "store and forward.")

## ROUTINE OPERATION OF AN AMATEUR STATION (CH 12)

---

### 1. Common Courtesy (Primarily HF):

- a. Before transmitting on any frequency, **listen** to see if that frequency is open.
  - i. Ask if the frequency is occupied: "Is this frequency in use?" on SSB, or "QRL" in CW.
- b. If you have contacted another station, and your signal is perfectly readable and very strong, **reduce your output power**.
- c. To minimize interference when **tuning-up your (tube) transmitter**, first tune into a dummy load.
- d. No station or net has "rights" to any frequency. If your desired frequency is occupied, move to a nearby frequency.
  - i. Notwithstanding 1.d, it is common courtesy to yield a frequency to established nets.
  - ii. If interference arises during a QSO due to changing band conditions, move to a clear frequency.
  - iii. On SSB (either LSB or USB), minimum frequency separation from an ongoing QSO should be 3 KHz.

### 2. Band Plans are guidelines for using different operating modes within an amateur band.

### 3. HF Operation (SSB):

- a. By convention, LSB (lower sideband) is used on frequencies below 10 MHz (30 metres).
- b. By convention, USB (upper sideband) is used on frequencies above 10 MHz (30 metres).
- c. By convention, all SSB data communications are USB, regardless of band.
- d. To tell if a band is "open" to a particular distant location, listen for beacon stations, foreign broadcasts, or TV stations from nearby frequencies.

### 4. Phonetic Alphabet:

<b>A</b>	Alpha	<b>K</b>	Kilo	<b>U</b>	Uniform
<b>B</b>	Bravo	<b>L</b>	Lima	<b>V</b>	Victor
<b>C</b>	Charlie	<b>M</b>	Mike	<b>W</b>	Whiskey
<b>D</b>	Delta	<b>N</b>	November	<b>X</b>	X-Ray
<b>E</b>	Echo	<b>O</b>	Oscar	<b>Y</b>	Yankee
<b>F</b>	Foxtrot	<b>P</b>	Papa	<b>Z</b>	Zulu
<b>G</b>	Golf	<b>Q</b>	Quebec		
<b>H</b>	Hotel	<b>R</b>	Romeo		
<b>I</b>	India	<b>S</b>	Sierra		
<b>J</b>	Juliette	<b>T</b>	Tango		

### 5. Measuring signal-strength:

- a. Signal strength is measured with an S-Meter.
- b. One S-unit equals (roughly) 6 dB power increase/decrease
- c. One S-unit equals (roughly) 4 times power increase/decrease

### 6. Jargon and Prosigns:

- a. **CQ** means: **Calling any station**.
- b. **DE** means **from**.

- c. **K** means **any station can transmit**.
    - i. **KN** means I'm expecting only the station I'm talking with to respond.
    - ii. **DX** means distant station.
  - d. **73** means **best regards**.
2. **Signal Reports:**
- a. **RST** means **readability, signal strength, tone**.
  - b. **Tone** is for CW-only.
  - c. **R:** 1-5, **S:** 1-9, **T:**1-9
    - i. **5x9 +20** means fully readable, and signal strength is 20 dB over S9.
7. **Calling 'CQ':**
- d. SSB Calling: CQ CQ CQ this is VE3FYN VE3FYN VE3FYN
  - e. SSB Answering: VE3FYN this is Victor Echo Three Alpha Kilo XRay
  - f. CW Calling: CQ CQ CQ de VE3FYN VE3FYN VE3FYN
  - g. CW Answering: VE3FYN VE3FYN de VE3AKX VE3AKX
8. **Morse Code (CW) Courtesy:**
- h. Do not send faster than you can receive.
  - i. Minimum CW frequency separation is 150 to 500 Hz.
  - j. In full-break-in telegraphy, incoming signals may be received between transmitted dots and dashes.
3. **Q-Codes:**
- a. Used in Morse Code to abbreviate complex statements or questions.
  - b. Each Q-code can be a question (with ?) or a statement.
  - c. **QRS:** Send more slowly
  - d. **QTH:** My location is...
  - e. **QRL?:** Is this frequency in use? Or Are you busy?
  - f. **QRM:** I am experiencing interference (man-made noise).
  - g. **QRN:** I am experiencing static (natural noise).
  - h. **QRZ:** Who is calling me?
  - i. **QRX:** I will call you again.
  - j. **QSO:** a contact.
  - k. **QSL:** confirmation of a contact (also QSL Card).
4. **Emergency Transmissions:**
- a. Transmit **SOS** (CW) and **MayDay** (phone) only in life-threatening distress situations.
  - b. **Distress call priority** (L -> H): Urgent -> Distress
  - c. If you are in a QSO and you hear a distress call, immediately take the call.
    - i. If you hear distress traffic and cannot provide assistance, listen until you are certain help will be forthcoming.
  - d. To break into a repeater QSO in a **distress** situation (not emergency), say: "break" twice, then your callsign.
  - e. You should be able to operate your station without using commercial AC power, so you may provide communications in an emergency.
  - f. The most important accessory for your handheld radio in an emergency is extra sets of charged batteries.
  - g. A portable dipole antenna would be useful for setting-up during an emergency.
5. **Azimuthal maps** show the correct direction to orient a directional antenna.
- a. An azimuthal map should be centred on your QTH.

- b. If you cannot hear a distant station via the short path (and others can), try the long-path. (This refers to aiming your antenna to take the longer route around the Earth to your intended station.)
  - c. A directional antenna oriented in the long-path is pointed 180 degrees from the short-path heading.
6. **Logbooks** are not required by Industry Canada, but they are useful for recording calls for awards, and for resolving interference complaints.
- a. **UTC:** Universal Time Coordinated, or GMT.
  - b. CHU, WWV or WWVH are accurate sources of current UTC.
9. **Repeaters:**
- c. Repeaters increase the range of portable and mobile stations.
    - i. They do this by simultaneously sending and receiving on separate frequencies. On the two metre band, these frequencies are 600 KHz apart.
  - d. They may also have telephone access, called an **autopatch**.
  - e. To make a contact on a repeater, say the callsign of the station you want to contact, then your own callsign.
    - i. If you need to make your callsign better understood, use International Phonetics.
  - f. It is good practice to pause between transmissions, and to keep transmissions short, to allow other stations to break-in.
    - i. If you must break-in during a conversation, state your callsign during a break between transmissions.
  - g. Use plain English on repeaters. Q-codes should be restricted to CW and HF.
    - i. We don't use 10-codes in amateur radio.
  - h. Repeater **time-out-timers** limit how long someone can transmit on the repeater.
  - i. A **CTCSS** or **PL tone** is a subaudible tone transmitted with your signal that triggers the repeater to accept your signal.
    - i. PL tones are used by some repeaters, usually in areas where there are many repeaters, or where interference is an issue.
10. **Simplex operation** is preferred over the repeater when a contact is possible without the repeater.
- j. To test for simplex operation while on the repeater, switch to the repeater's **input frequency**, and see if you can hear the other station.
  - k. Local simplex operation should be on **VHF and UHF** frequencies to avoid interference on HF bands capable of long-distance communications.

Simplex operation should not be on the repeater frequency, as the repeater cannot change its frequency.

## MODULATION AND TRANSMITTERS (CH 13)

---

1. CW (**Continuous Wave**) Modulation generates an RF wave of a single frequency and amplitude, which is broken to produce Morse Code characters.

Strictly speaking, CW is not a form of modulation, as the carrier wave is not modified. It is only a modulation system in the symbolic sense, that it is one way we add information to a wave, in this case by making and breaking the wave. The tone you hear at the receiving end is added by your receiver.

2. AM (**Amplitude Modulation**) combines the audio signal with the RF carrier wave, to produce an “envelope” which varies in amplitude according to the shape of the audio signal.
  - a. 100% modulation occurs when the RF waveform drops to 0 volts at the lowest part of the audio signal.
  - b. In Amateur Radio radiotelephony (phone), the maximum allowable modulation is 100%, as signals will be distorted beyond that point.
3. SSB (**Single Sideband**) eliminates either the upper or lower half of the carrier wave (which is a duplicate) and also the carrier wave.
  - a. The balanced modulator eliminates the carrier signal. It is reinserted at the receiver.
  - b. This reduces the bandwidth needed to carry the same information.
  - c. This also increases the effectiveness of the same power output.
4. FM (**Frequency Modulation**) varies the frequency of the carrier wave in accordance with the modulation of the audio wave.
  - a. FM is preferred for local VHF/UHF communications because of its high fidelity.
  - b. FM is not used below 29.5 MHz, because the allowed bandwidth is too narrow.
  - c. The **capture effect** causes only the loudest of two FM signals on the same frequency to be demodulated.
5. PM (**Phase Modulation**) is a variation on FM, produced by a reactance modulator.

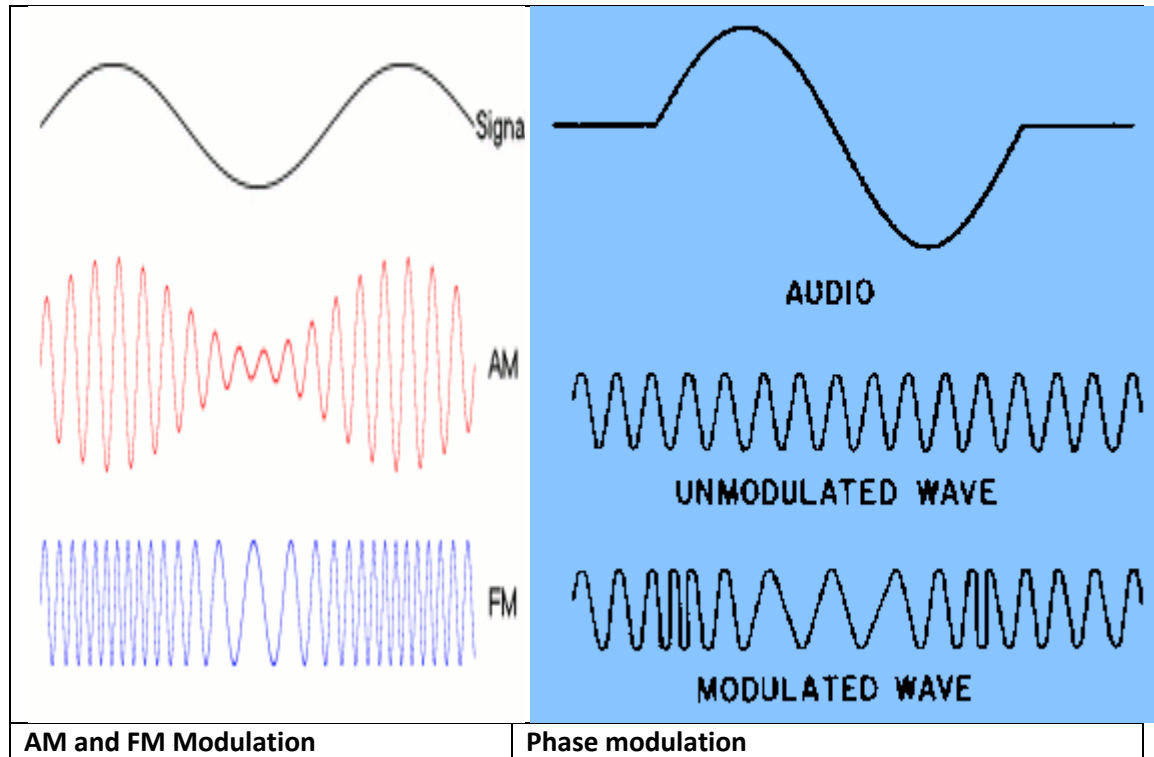

6. A **poorly matched antenna** or feedline will present an incorrect load (high SWR) to the transmitter, which may overheat the final transmitter stage.
  - a. Slight mismatches will result in lower antenna radiation.
  - b. The difference between the input power to your transmitter finals and the output power can be explained by the losses dissipated as heat.
  
7. Operating with your mic gain too high or too much speech processing can cause **spatter interference**. (Your signal will occupy more bandwidth than it should.)
  - a. In SSB operation, the **ALC** (Automatic level control) controls peak audio input to the final amplifier.
  - b. In SSB operation, mic gain should be adjusted for slight movement of the ALC meter on modulation peaks.
  - c. In FM, reduce your modulation by talking farther from, or not directly into, the mic.
  
8. The **RF signal** (oscillations) may be generated by a crystal, which creates a wave at a specific frequency; or by a variable-frequency oscillator.
9. **RF oscillators** should be electrically and mechanically stable to prevent frequency drifting.
  - a. By regulation, amateur radio transmitters must hold their frequency as well as a crystal-controlled transmitter.
  
10. **Peak envelope power** refers to the average power supplied to an antenna during one RF cycle at the crest of the modulation envelope.

11. **Typical Bandwidth:**

- a. **CW:** 150 – 500 Hz
- b. **AM:** 6 KHz (twice the audio frequency range)
- c. **SSB:** 2-3 KHz (the audio frequency range)
- d. **FM:** 10-20 KHz
- e. **RTTY:** 250-500 Hz

**12. Digital Transmissions:**

- a. Binary data (ones and zeroes) are converted to signals called **mark** and **space**.
- b. RTTY uses a seven bit Baudot Code.
- c. Packet uses eight bit ASCII Code, and the AX-25 protocol.

**13. AMTOR Transmissions:**

- a. Mode A uses ARQ (Automatic Repeat Request) and is an error-correcting mode used after contact has been established between two stations.

**14. Packet Radio:**

- a. A **digipeater** is a packet radio that stores then retransmits data packets it receives.
- b. When two stations are **connected**, they are sending information only to each other, and are sending error-correcting bits.
- c. When a station is **monitoring** in packet, that station is displaying messages not necessarily sent to it, and is not replying to the message.
- d. A **packet radio network** is a way of connecting packet radio stations so data can be sent over long distances.
- e. A transceiver and computer are connected in packet via a **TNC** (terminal node controller), which is like a modem.
- f. VHF Packet typically operates at **1200 baud**.

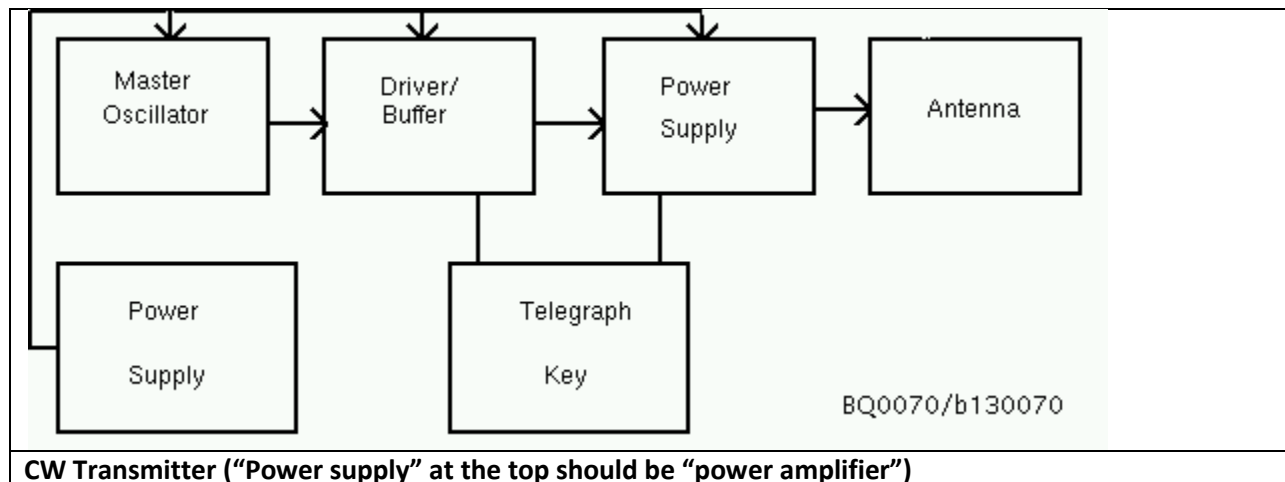

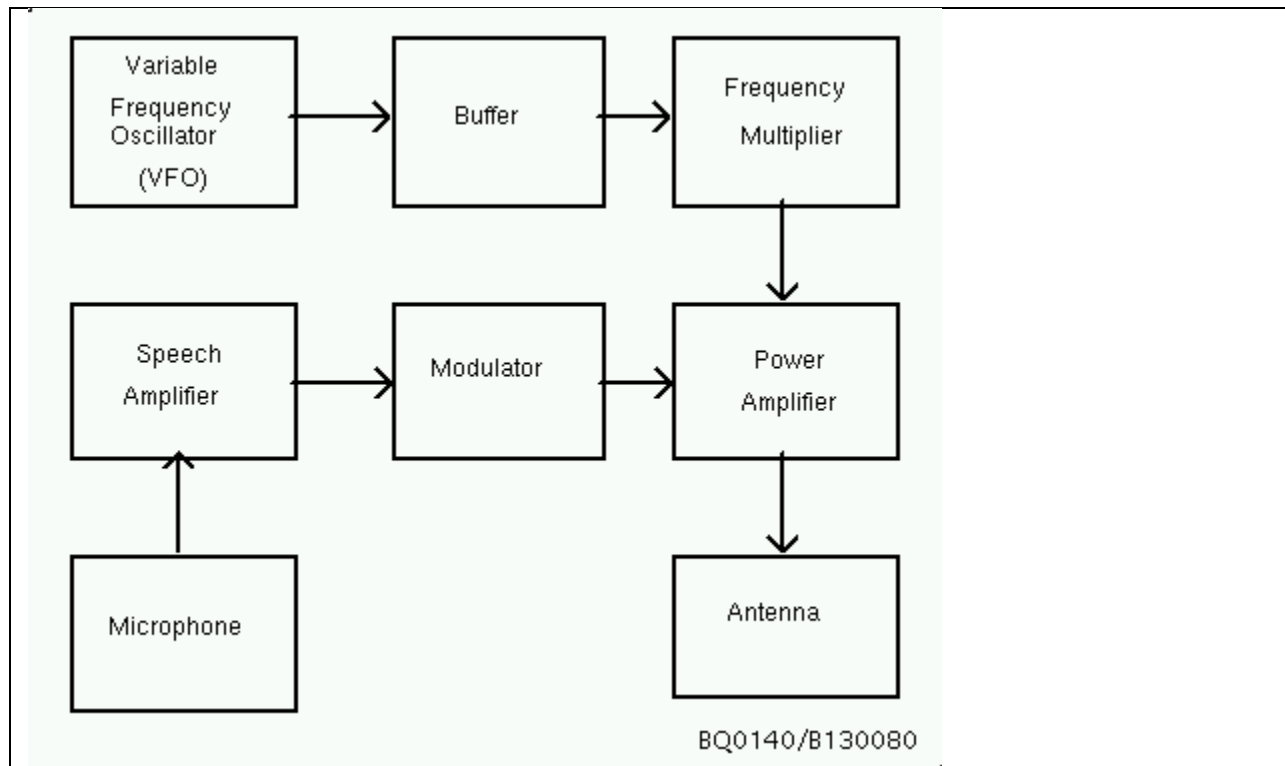

**AM Transmitter (The power amplifier also combines the audio with the carrier wave)**

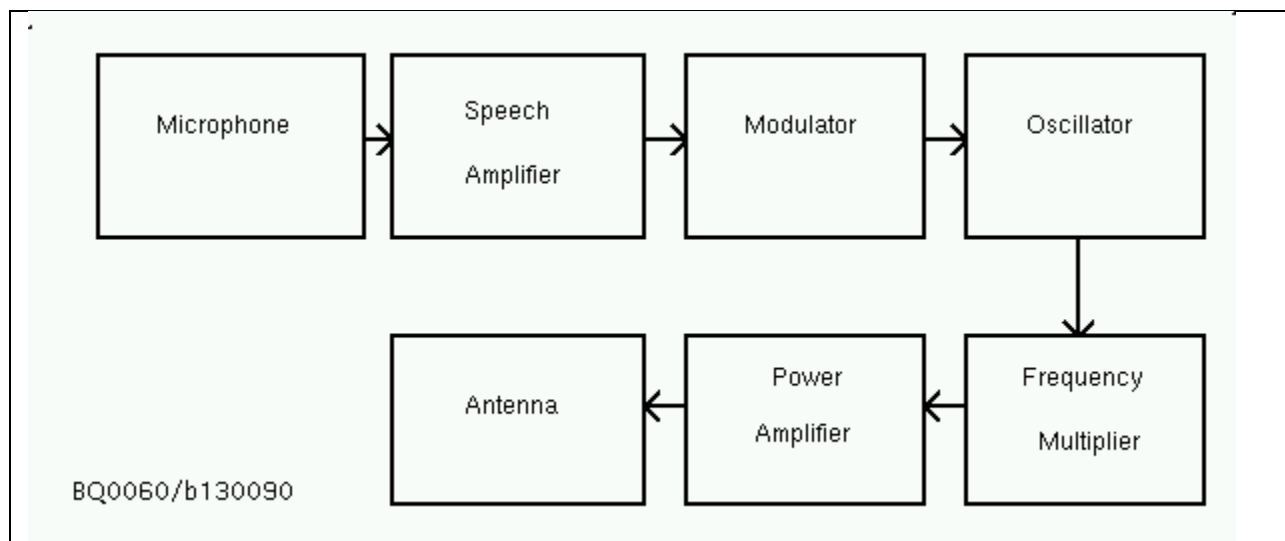

**FM Transmitter**

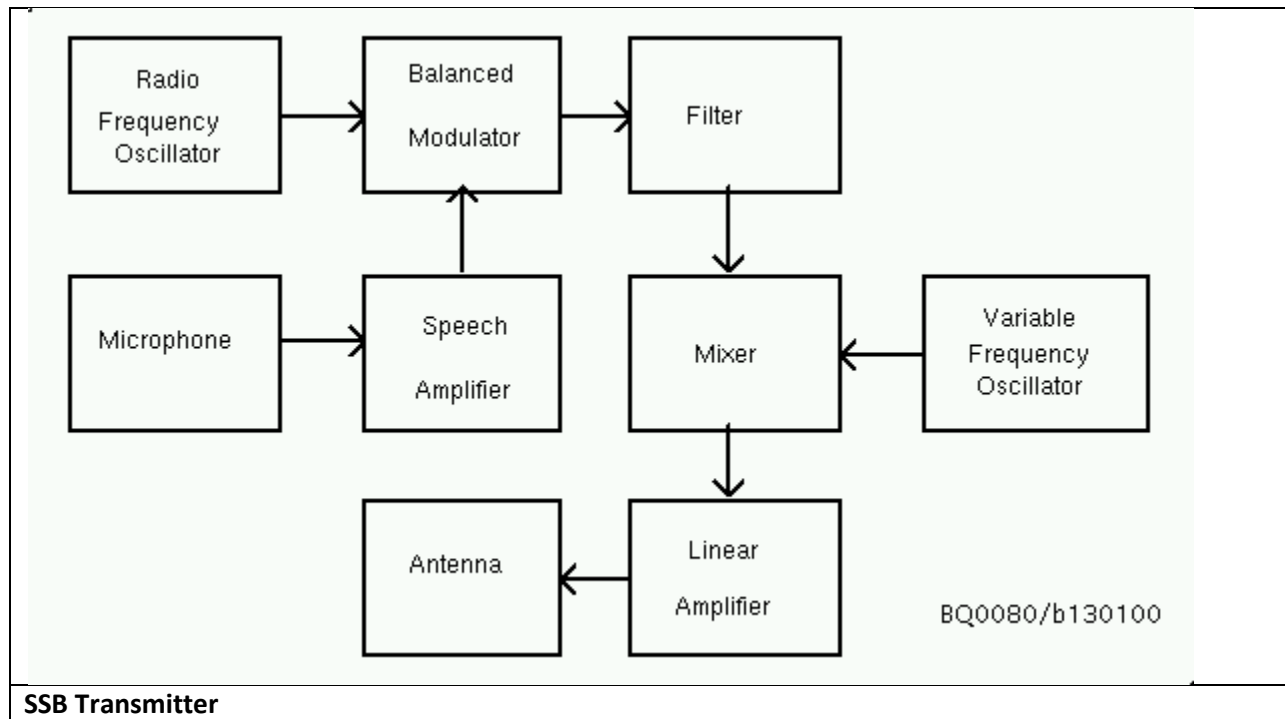

**SSB Transmitter**

## RECEIVERS (CH 14)

1. A **product detector** demodulates an SSB signal.
2. In **SSB**, the **beat frequency oscillator** (BFO) reproduces the missing carrier signal.
  - a. In **CW**, the **beat frequency oscillator** (BFO) varies a few hundred hertz from the carrier signal, to produce the tone.
3. The **local oscillator** reduces the incoming signal to a fixed intermediate frequency.
  - a. Incoming signal – local oscillator = IF
4. A **notch filter** can attenuate an interfering carrier or CW signal while receiving an SSB transmission.
5. Receivers are measured primarily for **sensitivity, selectivity and stability**.
  - a. Receiver sensitivity is measured in **SINAD** at a given input level, which is the ratio of signal plus noise, to noise.
  - b. A less sensitive receiver will produce more noise or less signal.
6. From narrowest bandwidth to widest, the order of these popular modes is:  
**CW, RTTY, SSB, FM**
7. An **SSB filter** is typically 2.0 – 3.0 KHz wide.
  - a. A **CW audio** filter is typically 150 – 500 KHz wide.
  - b. Typical **CW tones** are generated at 700-800 Hz.

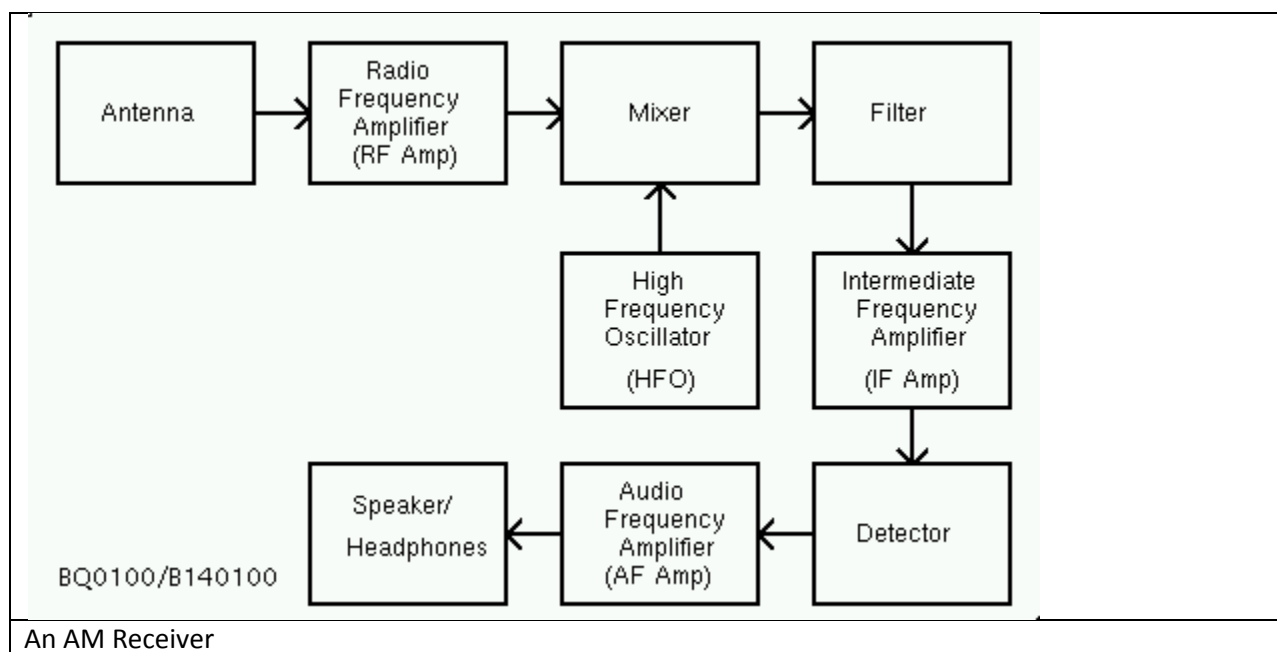

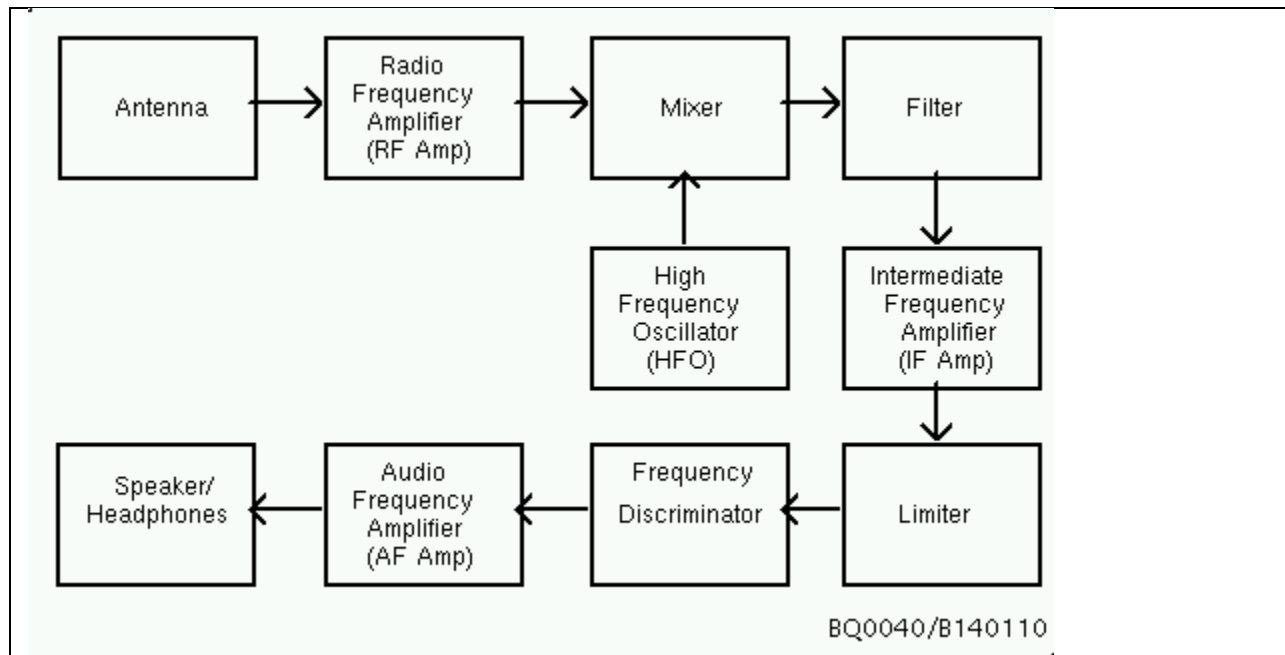

An FM Receiver

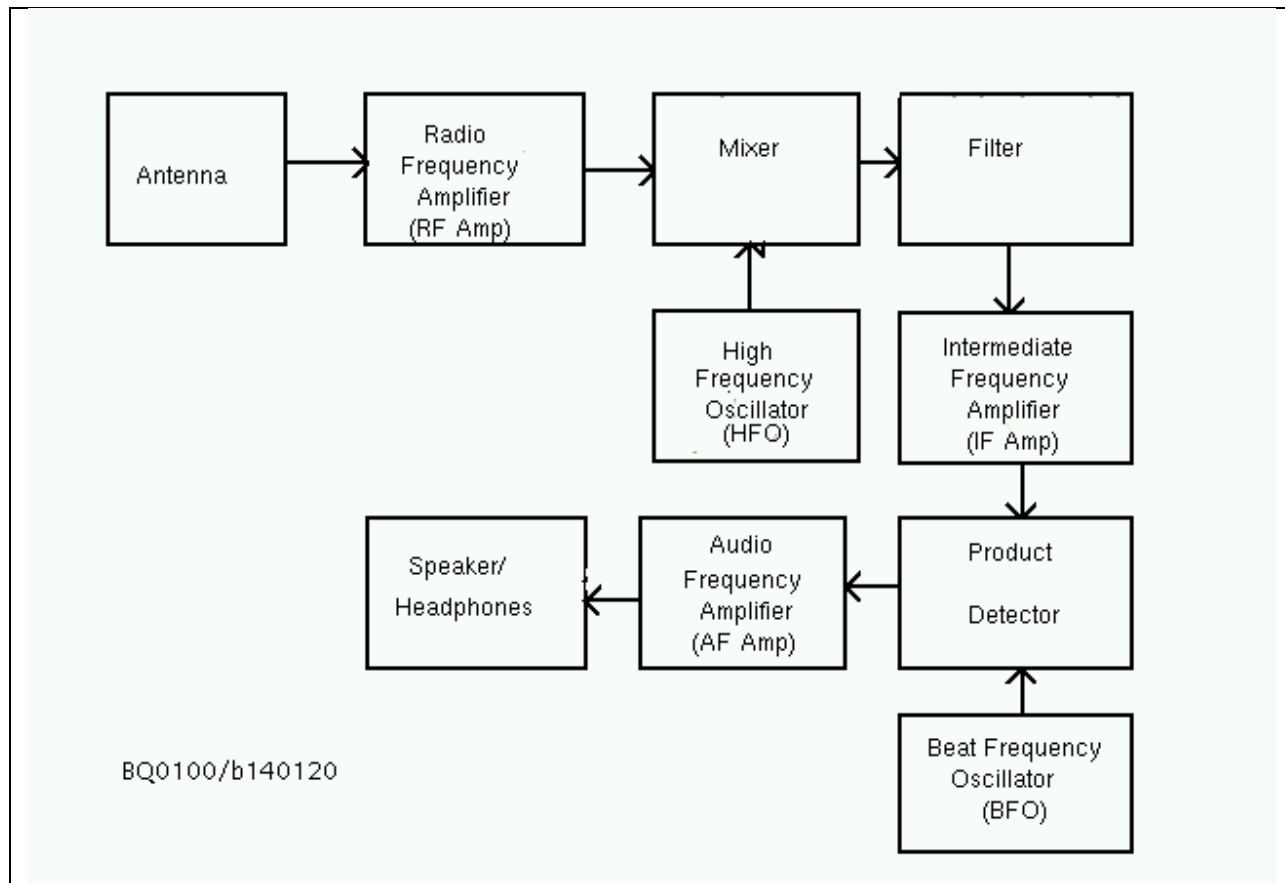

An SSB / CW Receiver

## INTERFERENCE (CH 15)

---

1. If the field strength at the location of equipment experiencing interference is less than **1.83 volts per metre**, it is deemed that the problem is the affected equipment's lack of immunity.
2. **Broadcast transmitters** are not included in the list of field strength criteria for resolution of immunity complaints.
3. **Radio-sensitive equipment** is defined as: "any device, machinery, or equipment other than radio apparatus, the use or functioning of which is or can be adversely affected by radio communication emissions."
4. **Receiver overload** or **Front-end overload** is interference caused by strong signals from a nearby transmitter.
  - a. **Front-end overload** is the cause of RFI if the interference is the same regardless of what frequency (or band) is used by the transmitter.
5. **Cross-modulation** interference is when (de)modulation from (or rectification of) an unwanted signal is heard in addition to the desired signal. It is heard as the undesired signal in the background of the desired signal.
6. Connecting a **high-pass filter** to a TV (VHF/UHF) can prevent front-end overload or cross-modulation from a nearby HF station.
7. When a nearby transmitter overloads the **audio stages** of a broadcast receiver, the transmitted signal can appear wherever the receiver is tuned
  - a. **By-pass capacitors** can reduce audio-frequency interference in home entertainment systems.
8. If a properly operating amateur station is causing interference in a **nearby telephone**, the phone company can install RFI filters in the phone.
9. **Audio rectification** of an **SSB** signal in a public address system will result in distorted speech from the transmitter's signals.
  - a. **Audio rectification** of a **CW** signal in a public address system will result in on and off humming or clicking.
  - b. When a broadcast receiver is experiencing audio rectification, or cross-modulation from an amateur station, the amateur's signal will be heard across the entire dial of the broadcast receiver.
  - c. **Properly grounding your station equipment** can reduce audio rectification in nearby equipment.
10. **Audio wires** can act as antennas, picking up unwanted signals.
  - a. Adding a **ferrite core** to the wire can minimize this effect.
  - b. Shortening the wires can also help.
11. CW key-clicks are caused by the too sharp a rise and decay in the making and breaking of the circuit (poor waveform shape) by the morse code key.
  - a. Key-click filters can prevent CW **key-clicks**. (Did I even have to say that?)

- b. A key-click filter is a choke and capacitor at the key.
12. **Spurious emissions** are RF emissions on frequencies other than the intended transmit frequency.
- a. Poor shielding in the radio can cause this.
13. **Parasitic oscillations** are emissions at (multiple) harmonic frequencies developed within the transmitter oscillator stage.
- a. These harmonics can be either above or below the fundamental frequency and can result in out-of-band transmissions.
  - b. **Multiband antennas** connected to poorly tuned transmitters can exhibit harmonic radiation.
  - c. **Low-pass filters** at the transmitter can reduce harmonic radiation. On modern transceivers, these are generally built-in.
  - d. 15 metres =  $20 \text{ MHz} * 3 = 60 \text{ MHz}$ , Channel 3 in the TV bands. Therefore, a 15 metre transmission can cause (3<sup>rd</sup>) harmonic radiation on channel three.
  - e. 10 meters =  $30 \text{ MHz} * 2 = 60 \text{ MHz}$
14. Pass and reject filters are placed between the transmitter output and the feedline.
15. **Notch filters** block RF above and below the desired frequency.
16. **Band-pass filters** pass frequencies within a certain range.
17. **Band reject filters** reject frequencies outside of a range.
18. **Low-pass filters** pass low (HF) frequencies, and reject high (VHF) frequencies.
- i. **An HF low-pass filter** will pass frequencies below 30 MHz.
19. The **impedance** of any filter should match the transmission line.
20. **Splatter interference** is caused by overmodulation of a transmitter (flat-topping), caused by too much microphone gain. (Over-driven stages can also lead to harmonic radiation.)

1. **Health Canada** published safety guidelines for the maximum limits of RF energy near the human body.
  - a. The document is called **Safety Code 6**.
  - b. RF exposure heats body tissue. The eyes are most sensitive.
  - c. According to Safety Code 6, the most dangerous frequencies are **30 – 300 MHz** (therefore the exposure limits are the lowest in this range).
    - i. Between 10 and 300 MHz, the maximum exposure to the public is 28 VRMS/metre (E-Field).
  - d. The maximum safe power output of hand-held radios is not specified, because HTs operating below 7 watts and below 1 GHz are no longer exempt, since 1999.
    - i. Handheld radio antennas should be kept away from your head.
  - e. Below 300 MHz, permissible exposure levels decreases as frequency increases.
  - f. Above 300 MHz, permissible exposure levels increase.
  - g. Above 1 GHz, eye damage can occur.
2. A key-operated switch on the power line to your radio shack can prevent unauthorized use.
3. In your car, disconnecting the microphone when not in use can prevent unauthorized use.
4. High –voltage power supplies often have switches that automatically turn off power when the cabinet is opened, to reduce the chances of electric shock.
5. As little as 1/10 Amperes travelling through the human body can be fatal.
  - a. At 30 volts, enough current can travel through the body to be dangerous.
  - b. The heart is primarily affected by electrical current.
  - c. When responding to a person with an RF burn, turn off all equipment first.
6. Before examining any mains operated equipment, turn off the equipment and unplug it.
  - a. Fault-finding (probing it while live) is not recommended due to the risk of shock.
  - b. The chassis of any mains-powered equipment should be connected to the green (ground) wire in the AC line to prevent the chassis developing a voltage relative to ground.
7. The chassis of all station equipment should be grounded, for protection from electric shock.
  - a. If a separate earth ground is not possible, a cold water pipe is an alternative.
  - b. A long ground wire (say 33 feet) will act more like an antenna than a ground wire, potentially causing RF burns. Therefore, keep your ground wires short.
  - c. Eight foot (2.5 metres) copper-clad steel makes an effective ground rod.
8. Grounding all antenna and rotator cables when not in use can protect from lightning damage.
  - a. Disconnecting equipment from power lines and antenna cables can protect it from lightning damage.
9. Proper climbing gear should be worn whenever working on a tower.

- a. Ground crew should wear hard hats.
10. Horizontal antennas should be placed out of reach, to prevent RF burns.
  11. Ground-mounted antennas should be placed away from normal human activity, to prevent RF burns.
  12. To prevent RF burns, ensure transmitting equipment is off and disconnected before working on antennas.

**END of *Basic Course Student Notes***